



FREZY KRAŹKOWE

MILLING CUTTERS

FORMFRÄSER

РОЛИКОВЫЕ ФРЕЗЫ

DIN 856

Frezy półokrągłe wypukłe

Convex milling cutters

Halbrund-Profilfräser (konvex)

Фрезы выпуклые

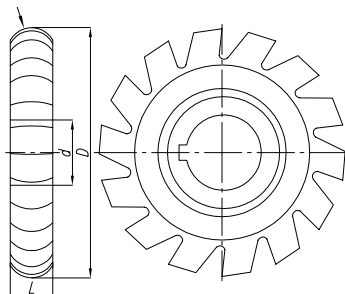
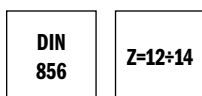

R (h11)	D (js16)	d (H7)	L	z	HSS	
					Code No 0641-593-	
1	50	16	2	14	200103	●
1.25	50	16	2.5	14	200144	●
1.5	50	16	3	14	200156	●
1.6	50	16	3.2	14	200205	●
1.75	50	16	3.5	14	200259	●
2	50	16	4	14	200307	●
2.25	63	22	4.5	12	200409	●
2.5	63	22	5	12	200500	●
2.75	63	22	5.5	12	200602	●
3	63	22	6	12	200704	●
3.15	63	22	6.3	12	200717	●
3.25	63	22	6.5	12	200806	●
3.5	63	22	7	12	200908	●
3.75	63	22	7.5	12	201002	●
4	63	22	8	12	201104	●
4.25	63	22	8.5	12	201206	●
4.5	63	22	9	12	201308	●
4.75	63	22	9.5	12	201400	○
5	63	22	10	12	201501	●
5.25	80	27	10.5	12	201513	●
5.5	80	27	11	12	201603	●
6	80	27	12	12	201705	●
6.3	80	27	12.6	12	201718	●
6.5	80	27	13	12	201807	●
7	80	27	14	12	201909	●
7.5	80	27	15	12	202003	●
8	80	27	16	12	202105	●
8.5	100	32	17	12	202209	●
9	100	32	18	12	202309	●
9.5	100	32	19	12	202400	●
10	100	32	20	12	202502	●
11	100	32	22	12	202604	●
12	100	32	24	12	202706	●
12.5	100	32	25	12	202808	●
13	125	32	26	12	202900	●
14	125	32	28	12	203004	●
15	125	32	30	12	203106	●
16	125	32	32	12	203208	●
17	125	32	34	12	203300	○
18	125	32	36	12	203401	●
19	125	32	38	12	203503	○
20	125	32	40	12	203605	●
22	130	40	44	12	203707	○
22.5	130	40	45	12	203748	○
24	145	40	48	12	203809	○

DIN 855 A

Frezy półokrągłe wklęsłe

Concave milling cutters

Halbrund-Profilfräser (konkav)

Фрезы вогнутые

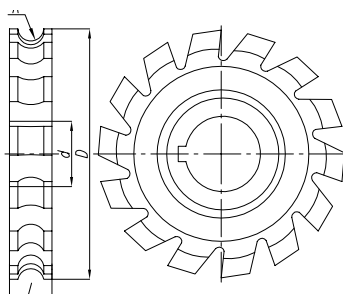
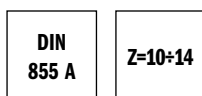

R (h11)	D (js16)	d (H7)	L	z	HSS	
					Code No 0641-593-	
1	50	16	6	14	220100	○
1.25	50	16	8	14	220112	○
1.5	50	16	8	14	220201	○
1.6	50	16	8	14	220303	○
1.75	50	16	8	14	220405	○
2	50	16	9	14	220507	●
2.25	63	22	10	12	220609	○
2.5	63	22	10	12	220700	●
2.75	63	22	12	12	220802	○
3	63	22	12	12	220904	●
3.15	63	22	12	12	220917	○
3.25	63	22	16	12	221009	○
3.5	63	22	16	12	221100	●
3.75	63	22	16	12	221202	○
4	63	22	16	12	221304	●
4.25	63	22	18	12	221406	○
4.5	63	22	18	12	221508	●
4.75	63	22	20	12	221600	○
5	63	22	20	12	221701	●
5.5	80	27	22	12	221905	●
6	80	27	24	12	222000	●
6.3	80	27	24	12	222013	○
6.5	80	27	28	12	222101	●
7	80	27	32	12	222203	●
7.5	80	27	32	12	222305	●
8	80	27	32	12	222407	●
8.5	100	32	36	12	222509	○
9	100	32	36	12	222600	●
9.5	100	32	36	12	222702	○
10	100	32	36	12	222804	●
11	100	32	40	12	222906	●
12	100	32	40	12	223102	●
12.5	100	32	40	12	223204	●
13	125	32	48	10	223306	○
14	125	32	48	10	223408	●
15	125	32	50	10	223500	●
16	125	32	50	10	223601	●
17	125	32	56	10	223703	○
18	125	32	56	10	223805	●
19	125	32	60	10	223907	○
20	125	32	60	10	224001	●
22	125	32	60	10	224103	○
22.5	125	32	60	10	224116	○
24	145	40	80	10	224120	○
25	145	40	80	10	224307	○

DIN 6513 R/L

Frezy ćwierćokrągłe

Corner rounding cutters

Viertelrund Profilfräser (konkav)

Фрезы профильные вогнутые

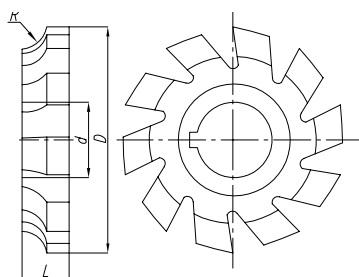

**DIN
6513
R/L**

Z=10+14

R (H11)	D (js16)	d (H7)	L	z	HSS			
					R - right	L - left		
					Code No 0641-593-	Code No 0641-593-		
1	50	16	4	14	100101	○	110008	○
1.25	50	16	4	14	100203	○	110100	○
1.6	50	16	5	14	100305	○	110201	○
2	50	16	5	14	100407	○	110303	○
2.5	63	22	5	12	100509	○	110405	○
3	63	22	6	12	100600	●	110507	○
3.15	63	22	6	12	100702	○	110609	○
4	63	22	8	12	100804	●	110700	○
5	63	22	10	12	100906	●	110802	○
6	80	27	12	12	101000	●	110904	○
6.3	80	27	12	12	101012	○	110917	○
8	80	27	16	12	101204	●	111100	○
10	100	32	18	10	101408	●	111304	○
12	100	32	20	10	101601	●	111508	○
12.5	100	32	20	10	101703	○	111600	○
16	125	32	24	10	101907	●	111803	○
20	125	32	28	10	102103	○	112000	○

DIN 842 A

Frezy kątowe jednostronne

Single angle shell end mills

Aufsteck-Winkelstrinfräser

Фрезы одноугловые торцевые

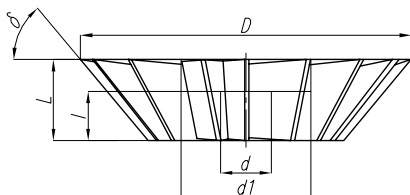

**DIN
842 A**

Z=16+36

δ	D (js16)	d (H7)	d1 (js15)	L (js14)	l (js14)	z	HSS	
							Code No 0641-573-	
45°	40	10	15	10	5.5	16	220109	●
45°	50	13	19	13	7.5	18	220404	○
45°	63	16	23	18	12	20	220700	●
45°	80	22	30	22	14	22	221008	●
45°	100	27	39	28	17	26	221303	●
45°	125	32	46	36	24	28	221609	●
45°	160	40	56	45	31	36	221904	○
50°	40	10	15	13	8	16	220200	○
50°	50	13	19	16	10	18	220506	○
50°	63	16	23	20	12	20	220801	●
50°	80	22	30	25	14	22	221100	●
50°	100	27	39	32	17	26	221405	●
50°	125	32	46	40	24	28	221700	○
50°	160	40	56	50	31	32	222009	○
55°	40	10	15	13	8	14	220241	○
55°	50	13	19	16	10	16	220550	○
55°	63	16	23	20	12	18	220855	○
55°	80	22	30	25	14	20	221140	○
55°	100	27	39	32	17	22	221459	●
55°	125	32	46	40	24	24	221754	○
55°	160	40	56	50	31	28	222052	○
60°	40	10	15	13	8	14	220302	○
60°	50	13	19	16	10	16	220608	○
60°	63	16	23	20	12	18	220903	●
60°	80	22	30	25	14	20	221201	●
60°	100	27	39	32	17	22	221507	●
60°	125	32	46	40	24	24	221802	●
60°	160	40	56	50	31	28	222100	○

DIN 1823A R/L

Frezy kątowe jednostronne

Single angle milling cutters

Winkelfräser

Фрезы одноугловые

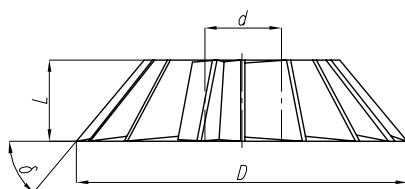

**DIN
1823 A
R/L**

Z=18+22

δ	D (js16)	d (H7)	L	z	HSS			
					R – right	L – left		
					Code No 0641-571-	Code No 0641-571-		
60°	50	16	12	18	200100	●	205104	○
65°	50	16	12	18	200201	○	205206	○
70°	50	16	12	18	200242	○	205219	○
75°	50	16	12	18	200303	○	205308	○
80°	50	16	12	18	200316	○	205310	○
85°	50	16	12	18	200329	○	205323	○
90°	50	16	12	18	200331	○	205337	○
60°	63	22	18	20	200405	●	205400	○
65°	63	22	18	20	200459	○	205413	○
70°	63	22	18	20	200507	○	205501	○
75°	63	22	18	20	200609	●	205603	○
80°	63	22	18	20	200700	○	205705	○
85°	63	22	18	20	200754	○	205807	○
90°	63	22	18	20	200802	○	205909	○
45°	80	27	16	20	201202	●	206309	○
60°	80	27	20	18	201304	●	206400	○
45°	100	32	22	22	201600	●	206706	○
60°	100	32	25	20	201701	●	206804	○

PN NFKa NFKb

Frezy kątowe jednostronne z promieniem

Single angle cutters with radius

Winkelfräser mit Radius

Фрезы одноугловые радиусные

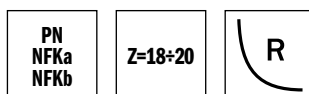
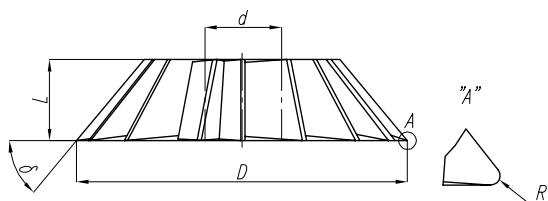

δ	D (js16)	d (H7)	L	z	R	HSS			
						NFKa	NFKb		
						Code No 0641-571-	Code No 0641-571-		
55°	50	16	10	18	0,5	027607	○	032101	○
60°	50	16	12	18	0,5	027709	○	032203	○
65°	50	16	12	18	0,5	027800	○	032305	○
75°	50	16	12	18	0,5	027902	○	032407	○
20°	63	16	6	18	1	028007	○	032509	○
25°	63	16	8	18	1	028109	○	032600	○
45°	63	22	12	20	0,6	028200	○	032702	○
50°	63	22	14	20	0,6	028302	○	032804	○
55°	63	22	16	20	0,6	028404	○	032906	○
60°	63	22	18	20	0,6	028506	○	033000	○
70°	63	22	18	20	0,6	028608	○	033102	○
75°	63	22	18	20	0,6	028700	○	033204	○
80°	63	22	18	20	0,6	028801	○	033306	○
20°	80	22	10	20	1,6	028903	○	033408	○
25°	80	22	12	20	1,6	029008	○	033500	○
30°	80	22	14	20	1,6	029100	○	033601	○
25°	100	27	16	20	1,6	029201	○	033703	○
30°	100	27	18	20	1,6	029303	○	033805	○

DIN 1823 B R/L

Frezy kątowe niesymetryczne

Unequal angle milling cutters

Winkelfräser, unsymmetrisch

Фрезы угловые несимметричные

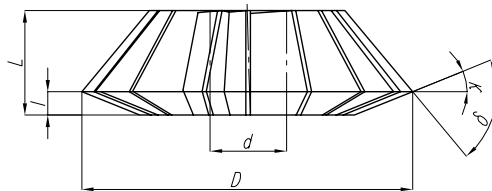

**DIN
1823 B
R/L**

Z=18+24

δ	χ	D (js16)	d (H7)	L (js16)	l	z	HSS			
							R - right	L - left		
							Code No 0641-572-	Code No 0641-572-		
70°	15°	50	16	14	2	18	010405	○	015400	○
75°	15°	50	16	16	2	18	010507	○	015501	○
80°	15°	50	16	16	2	18	010609	○	015603	○
90°	15°	50	16	18	2	18	010802	○	015807	○
60°	15°	63	22	14	3	20	011202	○	016207	○
70°	15°	63	22	18	3	20	011406	○	016400	○
75°	15°	63	22	18	3	20	011508	○	016502	○
80°	15°	63	22	20	3	20	011600	○	016604	○
60°	15°	100	32	28	5.5	24	012600	○	017605	○
65°	15°	100	32	32	5.5	24	012702	○	017707	○
70°	15°	100	27	36	6	20	012804	○	017809	○
75°	15°	100	27	36	6	20	012906	○	017900	○
80°	15°	100	27	36	6	20	013000	○	018005	○

PN NFKc / Kd

Frezy kątowe niesymetryczne z promieniem

Unequal angle milling cutters with radius

Winkelfräser, unsymmetrisch mit Radius

Фрезы угловые несимметричные радиусные

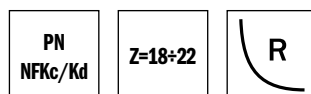
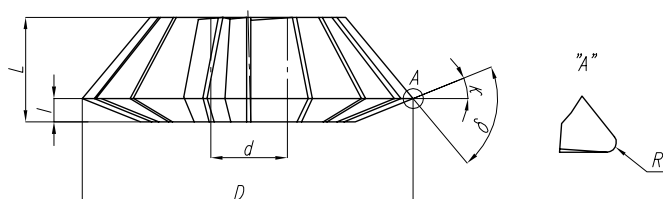

δ	χ	D (js16)	d (H7)	L (js16)	l	z	R	HSS			
								NFKc		NFKd	
								Code No 0641-572-		Code No 0641-572-	
55°	12°	50	16	12	2	18	0,5	027104	○	032108	○
60°	15°	50	16	12	2	18	0,5	027206	○	032200	○
65°	15°	50	16	12	2	18	0,5	027308	○	032301	○
70°	15°	50	16	14	2	18	0,5	027400	○	032403	○
75°	15°	50	16	16	2	18	0,5	027501	○	032505	○
80°	15°	50	16	16	2	18	0,5	027603	○	032607	○
85°	15°	50	16	16	2	18	0,5	027705	○	032709	○
90°	15°	50	16	18	2	18	0,5	027807	○	032800	○
100°	25°	50	16	18	4,5	18	0,5	027909	○	032902	○
110°	25°	50	16	18	4,5	18	0,5	028003	○	033007	○
55°	12°	63	22	14	3	20	0,6	028105	○	033109	○
60°	15°	63	22	14	3	20	0,6	028207	○	033200	○
65°	15°	63	22	18	3	20	0,6	028309	○	033302	○
70°	15°	63	22	18	3	20	0,6	028400	○	033404	○
75°	15°	63	22	18	3	20	0,6	028502	○	033506	○
80°	15°	63	22	20	3	20	0,6	028604	○	033608	○
85°	20°	63	22	20	3,5	20	0,6	028706	○	033700	○
90°	20°	63	22	20	3,5	20	0,6	028808	○	033801	○
100°	25°	63	22	22	4	20	0,6	028900	○	033903	○
60°	15°	80	27	22	4,5	22	1	029004	○	034008	○
65°	15°	80	27	25	4,5	22	1	029106	○	034100	○
70°	15°	80	27	25	4,5	22	1	029208	○	034201	○
75°	15°	80	27	25	4,5	22	1	029300	○	034303	○
80°	15°	80	27	28	4,5	22	1	029401	○	034405	○
85°	15°	80	27	28	5,5	22	1	029503	○	034507	○

DIN 847

Frezy kątowe symetryczne

Double angle milling cutters symmetrical

Prismenfräser

Фрезы двухугловые симметричные

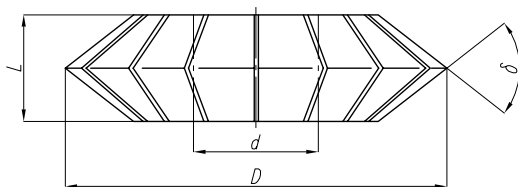

DIN 847	Z=16+30
--------------------	----------------

δ	D (js16)	d (H7)	L (js16)	z	HSS	
					Code No 0641-572-	
45°	50	16	8	22	199154	●
60°	50	16	10	20	199202	●
90°	50	16	14	16	199304	●
120°	50	16	14	16	199317	○
45°	63	22	10	24	200401	●
60°	63	22	14	22	200605	●
90°	63	22	20	18	200707	●
120°	63	22	20	16	200710	●
45°	80	27	12	26	200809	●
60°	80	27	18	24	200900	●
90°	80	27	22	20	201005	●
120°	80	27	25	20	201018	●
45°	100	32	18	30	201107	●
60°	100	32	25	28	201209	●
90°	100	32	32	22	201300	●

PN NFKe

Frezy kątowe symetryczne z promieniem

Double angle milling cutters with radius

Prismenfräser mit Radius

Фрезы двухугловые симметричные радиусные

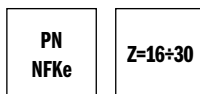
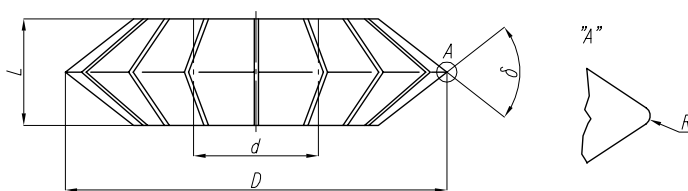

δ	D (js16)	d (H7)	L (js16)	z	R	HSS	
						Code No 0641-572-	
45°	50	16	8	22	0,5	047100	○
60°	50	16	10	20	0,5	047202	○
90°	50	16	14	16	0,5	047304	○
20°	63	16	6	18	1	047406	○
25°	63	16	8	18	1	047508	○
45°	63	22	10	24	0,6	047600	○
60°	63	22	14	22	0,6	047701	○
90°	63	22	20	18	0,6	047803	○
20°	80	22	8	20	1,6	047905	●
25°	80	22	10	20	1,6	048000	○
30°	80	22	12	20	1,6	048012	○
45°	80	27	12	26	0,8	048101	○
60°	80	27	18	24	0,8	048203	○
90°	80	27	22	20	0,8	048305	○
25°	100	27	14	24	2	048407	○
30°	100	27	16	24	2	048509	●
45°	100	32	18	30	1	048600	○
60°	100	32	25	28	1	048702	○
90°	100	32	32	22	1	048804	○

NFKc-SPEC

Frezy kątowe do kopiowania kluczy

Angle milling cutter for copying of keys

Winkelfräser

Фрезы угловые копирные для ключей

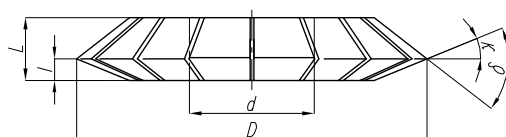

NFKc -SPEC	Z=110
-----------------------	--------------

δ	χ	D (js12)	d (H6)	L (h11)	l	z	HSS
80°	40°	80	16	5	1.3	110	Code No 0641-995-600101

Informacje techniczne

Parametry skrawania dla frezów promieniowych i kątowe

Technical data

Cutting data – milling cutters

Technische Hinweise

Технические информации

GRUPA I: dla frezów kątowych i przyrządkowych krążkowych
 GROUP I: for angle milling cutters
 Gruppe I. für Winkel- und Prismen-Zahnformfräser
 ГРУППА I: для угловых и призматических роликовых фрез

GRUPA II: dla frezów promieniowych krążkowych
 GROUP II: for radius milling cutters
 Gruppe II. für Radialzahnformfräser
 ГРУППА II: для радиусных роликовых фрез

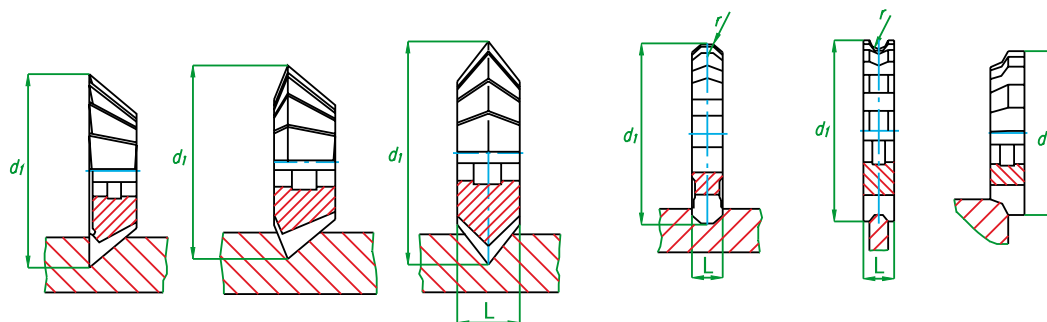

grupa mat. material group группа применения	HSS Vc m/min	dla średnicy for diameter Для диаметра	
		fz mm	D (mm)
		grupa 1, group 1 группа 1	grupa 2, group 2 группа 2
1.1	28	0,056	0,048
1.2	28	0,056	0,048
1.3	22	0,048	0,032
1.4	28	0,04	0,048
1.5	16	0,024	0,024
1.6	16	0,024	0,032
1.7	16	0,024	0,032
1.8	16	0,04	0,032
1.9			
1.10			
1.11			
2.1	18	0,024	0,048
2.2	18	0,024	0,048
2.3	12	0,024	0,032
3.1	22	0,064	0,064
3.2	18	0,048	0,048
3.3	28	0,048	0,048
3.4	34	0,048	0,064
3.5	10	0,024	0,032
4.1	22	0,096	0,064
4.2	18	0,032	0,04
4.3	10	0,024	0,032
5.1	18	0,096	0,064
5.2	16	0,048	0,048
5.3	8	0,032	0,032
6.1	18	0,064	0,064
6.2	28	0,064	0,064
6.3	34	0,048	0,064
6.4	8	0,032	0,032
7.1	80	0,064	0,048
7.2	200	0,056	0,04
7.3	56	0,048	0,032
7.4	200	0,064	0,032
8.1	96	0,056	0,04
8.2	56	0,064	0,048
8.3	56	0,064	0,048

materiały ze stopów tytanu i żaroodporne są frezowane współbieżnie
 titanium alloys or heat-resistant materials are climb-cut

Werkstücke aus Titanlegierungen und hitzebeständige Werkstücke werden mit Gleichlauf gefräst

материалы из сплавов титана и жароустойчивые фрезеруют синхроническим способом

grupa materiałowa, patrz str. 16

material group, see page 17

Werkstoffgruppe Seite 18

группа применения, смотри стр. 19